

INFORMATION ABOUT ORDERING CUSTOM KNIVES

Custom knife orders can be ordered in several different ways;

1. Fax an order to us at 603-732-4048
2. Mail a drawing to us at Williams & Hussey Machine Co Inc, 70 Powers St, Milford, NH 03055
3. Mail a small cross section ($\frac{3}{4}$ " minimum length) of stock to us. The section needs to look just the way you want it to look.
4. Email a DXF or PDF, file to us at, info@williamsnhussey.com

Other reminders

All drawings should be dimensioned with the molding width and height shown to enable us to cross check for any distortion in copying or faxing.

Please provide a base line (see illustration below) of your molding drawing. The base line reference allows us to ensure your profile is parallel to the stock base or is on an angle you have chosen, such as for use on a "V" block.

The knife blank extends at least $\frac{1}{8}$ " more on each side of the molding profile.

We are willing to confirm your knife details by fax. This ensures that you will get the knife you want the first time.

Clarification terms for special knives are detailed below:

CENTER PROFILE ONLY

Center profile knives where you only want to mold the center portion of your stock.

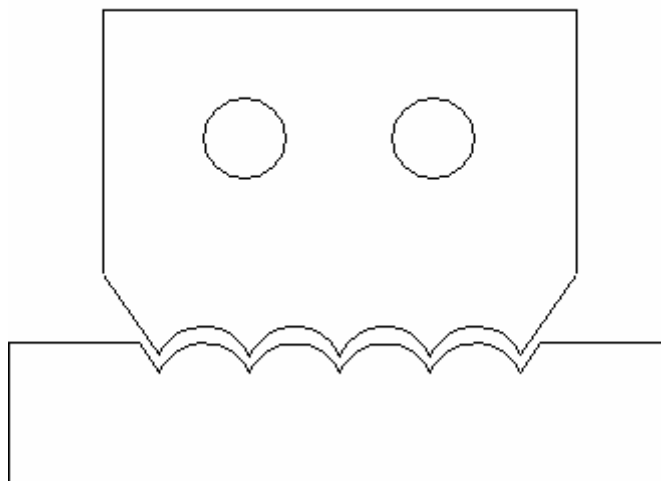

END PROFILE ONLY

End profile for curved molding or wide boards (please specify)

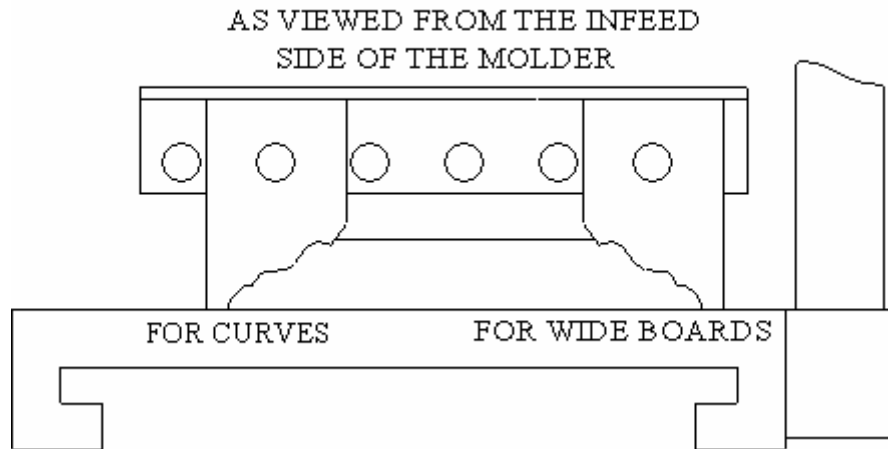

SYMMETRICAL

You may specify to have your knives made with a symmetrical pattern (mirror image on both sides) and if so please specify which side most accurately describes the detail of your profile. Please state if you desire to have the width of the molding maintained. Sometimes one side is longer than the other in the drawing you submit so it might be necessary to resize slightly.

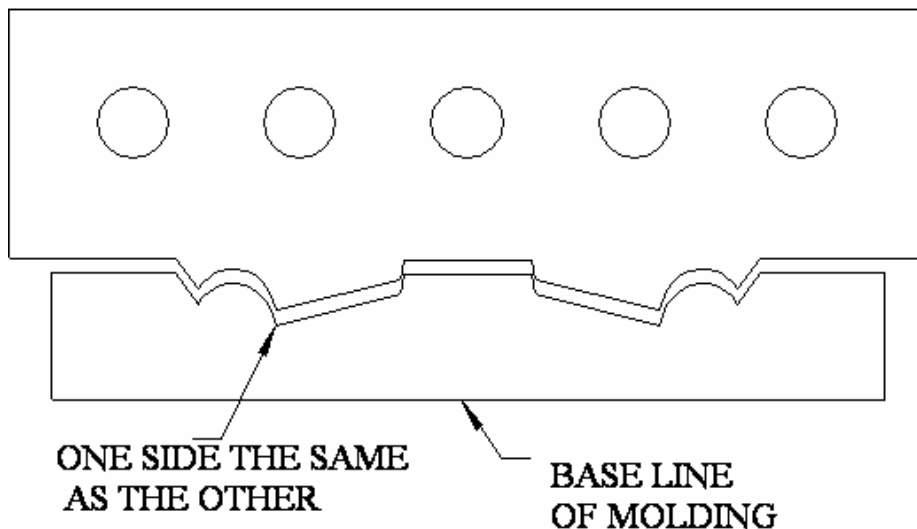

V-BLOCK

V-Block option for profiles that would normally be too deep to cut (NOT suitable for curved molding)

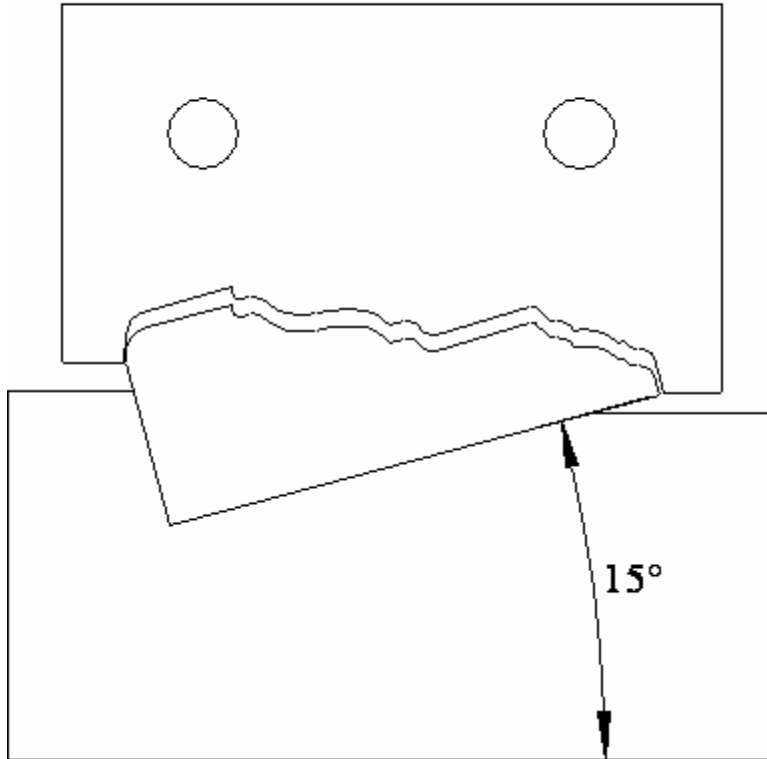

A drawing will be included with your knives to show you the angle of the V-Block to assist you with your setup.